

Rebecca 800x450-500-550-600-650-700-750

Rebecca 1000x450-500-550-600-650-700-750-800

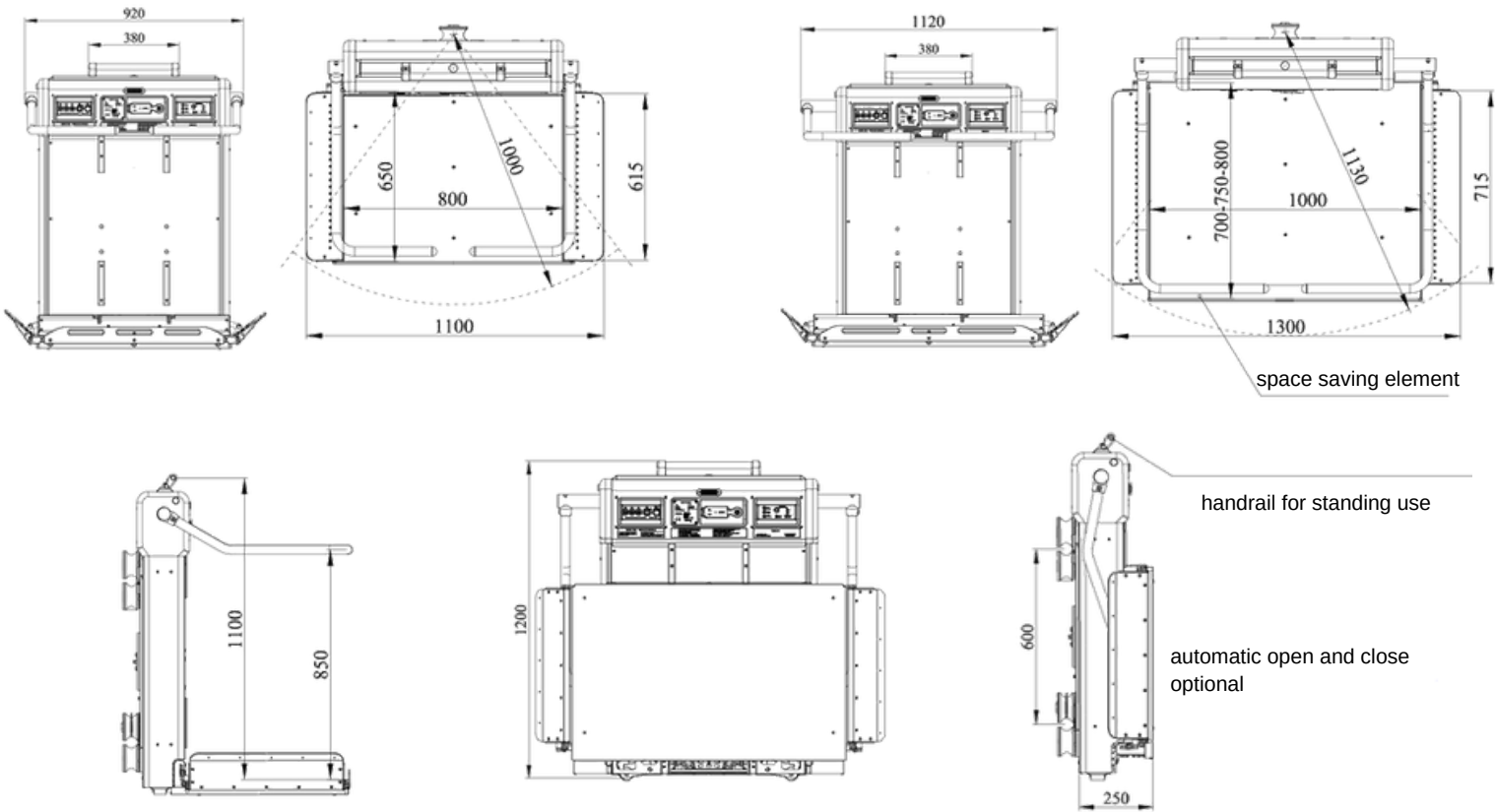

Loading platform calculation tab according to stair

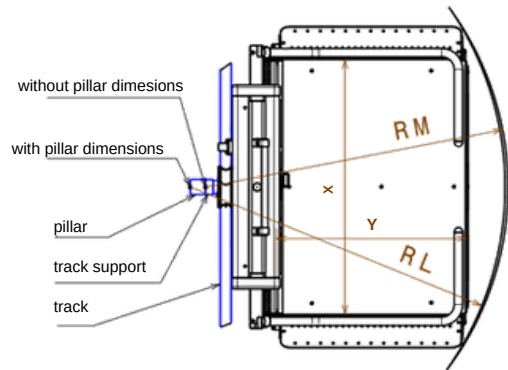
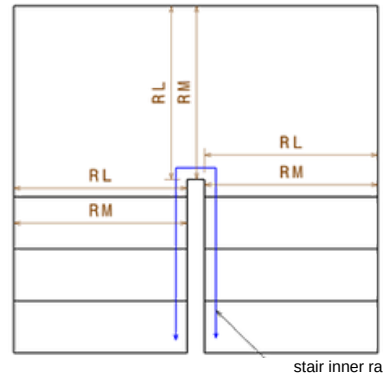

without pillar

| rebecca         | X    | Y   | RL   |
|-----------------|------|-----|------|
| rebecca 0845    | 800  | 450 | 850  |
| rebecca 0845+50 | 800  | 500 | 870  |
| rebecca 0850    | 800  | 500 | 955  |
| rebecca 0850+50 | 800  | 550 | 975  |
| rebecca 0855    | 800  | 550 | 1000 |
| rebecca 0855+50 | 800  | 600 | 1020 |
| rebecca 0860    | 800  | 600 | 1045 |
| rebecca 0860+50 | 800  | 650 | 1065 |
| rebecca 0865    | 800  | 650 | 1090 |
| rebecca 0865+50 | 800  | 700 | 1110 |
| rebecca 0870    | 800  | 700 | 1135 |
| rebecca 0870+50 | 800  | 750 | 1160 |
| rebecca 0875    | 800  | 750 | 1180 |
| rebecca 0875+50 | 800  | 800 | 1205 |
| rebecca 1070    | 1000 | 700 | 1180 |
| rebecca 1070+50 | 1000 | 750 | 1200 |
| rebecca 1075    | 1000 | 750 | 1225 |
| rebecca 1075+50 | 1000 | 800 | 1245 |

with pillar

| rebecca         | X    | Y   | RM   |
|-----------------|------|-----|------|
| rebecca 0845    | 800  | 450 | 800  |
| rebecca 0845+50 | 800  | 500 | 820  |
| rebecca 0850    | 800  | 500 | 905  |
| rebecca 0850+50 | 800  | 550 | 925  |
| rebecca 0855    | 800  | 550 | 950  |
| rebecca 0855+50 | 800  | 600 | 970  |
| rebecca 0860    | 800  | 600 | 995  |
| rebecca 0860+50 | 800  | 650 | 1015 |
| rebecca 0865    | 800  | 650 | 1050 |
| rebecca 0865+50 | 800  | 700 | 1070 |
| rebecca 0870    | 800  | 700 | 1085 |
| rebecca 0870+50 | 800  | 750 | 1110 |
| rebecca 0875    | 800  | 750 | 1130 |
| rebecca 0875+50 | 800  | 800 | 1155 |
| rebecca 1070    | 1000 | 700 | 1130 |
| rebecca 1070+50 | 1000 | 750 | 1150 |
| rebecca 1075    | 1000 | 750 | 1175 |
| rebecca 1075+50 | 1000 | 800 | 1195 |

# Rebecca

the stairlift of

**ENOK**  
Up to eQuality

Enok s.r.l.

Operational headquarters: S.S.113 km 249,15 - 90011 Bagheria (PA) - Italy

P.Iva: 06613460820 - REA: PA-402857

Phone: 091.8432602 - Mail: info@enoksrl.com - Pec: enok\_srl@pec.it

# Technical Characteristics

## REBECCA 5.2 automatic stairlift

### Automatic Model Designed for Independent Transportation of Wheelchair Users.

The REBECCA 5.2 stairlift platform is designed and manufactured in compliance with **UNI 9801 standards**, European Directive 2006/42 / CE and Ministerial Decree 14 June n 2 236 and in compliance with CEI 64-8 and Law 46/90, in particular in compliance with the specific standard for stair lifts UNI EN 81-40 of 2009.

The Rebecca Platform consists of :

### 1 - MACHINE BODY SPECIFICATIONS :

#### A) Traction group :

The traction unit, integral to the platform, consists of an electric motor powered at 24 Volts DC., through a battery system suitable for traction. The rated motor power of 400 ma

W The system is equipped with a battery charger operating at 220 Volts 50 Hz single phase. Speed Max The batteries are recharged automatically when the platform is located at the upper or lower stop points or, if necessary, at the intermediate stop floors. Traction takes place by means of traction wheels ( UNI EN 81-40 5.4.8 ) that move along the track consisting of two steel guides parallel to each other, grip is guaranteed even in the most unfavorable conditions by a traction control system.

The traction unit, power batteries, control and command equipment, electrical wiring are contained inside the machine body.

In the absence of mains electricity, the machine continues to operate until 80% of the battery charge is exhausted, corresponding to about 10 full runs of a plan. In the absence of mains electricity and in case of reaching the minimum level of charge of the batteries, a reserve is available that allows you to reach the lower floor.

The machine is equipped with a warning light and acoustic during the travel for the entire route, the signal goes off when the machine stops in its charging position. The machine body coatings are made of INO acciaio AISI 304 steel sheet laser cut and bent with numerical control machines.

In case of request ( optional )the panels can be coated with a PVC film to the customer's liking.

The machine is equipped with an emergency manual operation by handwheel and release of the electric brake.

### 2-SECURITY SYSTEMS :

The stairlift will be equipped with the following safety systems:

- speed limiter (UNI EN 81-40 5.3): coupled to a wheel that will slide along the track at the same time as the platform. In case of speeding, the limiter will trigger the parachute (UNI EN 81-40 5.3.1.3) which will progressively block the platform;
- protection for people who are using the stairlift

(UNI EN 81-40 5.5.6): the access ramps to the loading floor and the bottom of the platform are equipped with sensors that when encountering an obstacle will block the platform but will allow the operation in the opposite direction to the direction of travel to allow the removal of the obstacle; protection bottom loading floor, protection bottom structure, side protection s/

- protections for stair lift users (UNI EN 81-40 5.6.3.2):

they consist of 2 protection bars that wrap around the user and access ramps to the loading floor. The motion of the footboard will be prevented if the bars are not in a horizontal position and the grapples in an oblique position.

- electrical safety: the machine operates entirely in low voltage 24 V dc. A battery charger connected to the mains provides for the recharging of the batteries, in accordance with CEI 64-8 standards

### 3-LOADING PLATFORM

The loading platform consists of a folding table manually or automatically with a stationary machine, made of steel structure equipped with a non-slip sheet aluminum sheet (the sizes vary according to the available space). The nominal load of the platform is Kg. 250, the capacity Ma Kg Kg 300, tests done at Kg 375.

For the standard ( UNI EN 81-40 5.6.4 ) stairlifts installed in buildings open to the public, must be equipped with a min load floor of 10007750 to accommodate type B wheelchairs, the rated load must not be less than 250Kg / sqm.

The rebecca loading table can be adapted to the customer's needs by having 9 different sizes available ranging from 8004450 to 1000x

### 4-MOTORIZED LOADING TABLE AND PROTECTION ARMS:

The platform is equipped with a motorized drive system for closing and opening the platform and related protection arms. (if it is the motorized option requested by the customer )

THE PURPOSE of the motorized drive is to allow the use of the system in full autonomy by the user, avoiding the intervention of third people for the opening and closing of the platform and the arms protection.

**The behavior of automatism is as follows :**

1. recall of the platform by means of a button placed on the wall at a regulatory height, having the function of recall of the platform and opening of the same, positioning the arms in the boarding position.
2. once on board the user must hold the control wire that, in addition to allowing the control of the machine , disables the push buttons on the floors, with the press of the button relative to the direction of travel that you want to travel, closes the protection arm on the boarding side, then the stairlift starts in its run along the path of the stairs.
3. after use, the user will close the platform in a motorized way after storing the remote control in the appropriate housing. The closing operation of the loading table and the protective arms must be carried out by the floor push-buttons.
4. when the platform is closed, the protection bars will be positioned downwards between the platform and the machine body , in order to avoid forcing and attempted break-in by non-workers. The closed platform protection bands act as anti-greasing and anti-shock sensors as with an open platform.

## 5-TRACK :

The track consists of two tubular steel profiles with a diameter of about 42 mm. The conformation of the track is obtained by computer-controlled bending machine tools (CAD system) that ensure the perfect execution of the curved parts and the equidistance between the two guides. The track is smooth, without holes or teeth and will not require greasing or special care. The guides, being free of holes or teeth, can act as handrails for other users of the stairs in perfect safety.

The guides are fixed to the walls by means of special supports made of ino ancor steel profiles anchored by suitable fastening systems (chemical dowels). In the event that the walls turn out to be unsuitable for bearing the weight of the equipment or there is a need to install the installation on the side of the handrail it will be realized suitable supporting structure in metal profiles, finished with double coat of anti-rust paint and color finishing coat of choice of D. L., or ino struttura steel structure to be anchored to the steps of the staircase.

Given the particular type of coupling and traction system, the track will not require any type of lubrication and/or maintenance.

## 6-CONTROL EQUIPMENT (UNI EN 81-40 5.5.14) :

### On board the platform :

- Removable ignition key in off position and on position
- Hanging push-button panel connected with spiral cable with "UP – DOWN"controls

### On the floor :

- Removable ignition key
- Remote control ( portable or fixed) with "UP – DOWN" control panel and

"PLATFORM CLOSURE".

The recall and the reference to the floor is allowed only when the loading floor is closed, the maneuver must be carried out under the supervision of the user in compliance with the STANDARD in mode (with man present )

The pushbutton panels allow the operation of the platform only with the continuous pressing of the buttons and are powered in low voltage at 24 V. The pushbutton panel is positioned at a height between mm. 900 and mm. 1100 from the decking.

